

Flameproof Camera Enclosure

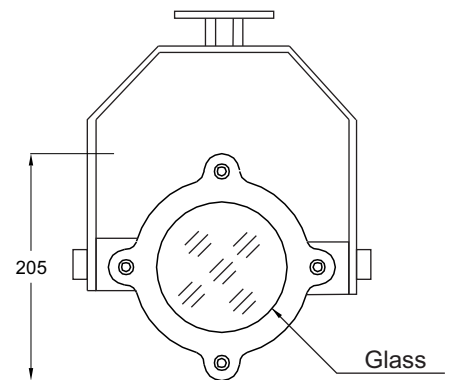

Model : FI/CMB/14

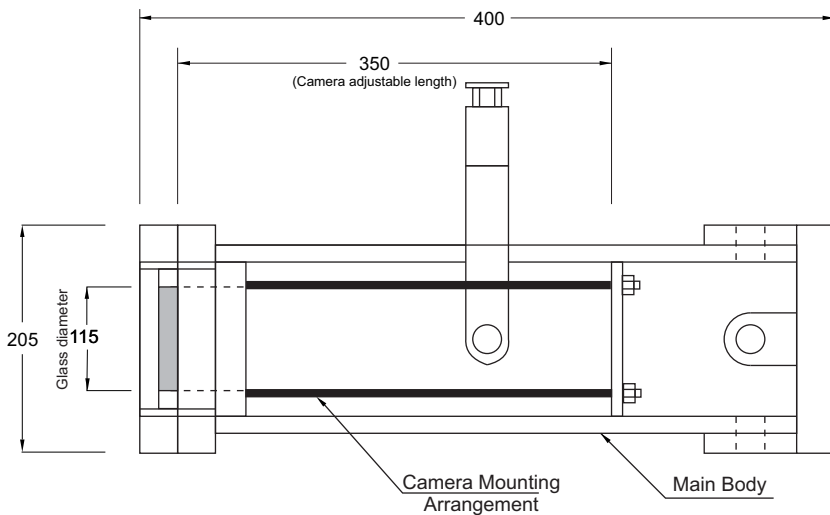

	SALIENT FEATURES
Operating Temp.	Up to 55°C
Humidity	90 % at 40°C
Enclosure	LM6, Aluminum
Coating	Powder coated
Dimension	As per drawing
Weight	10 Kg
Cable entry options	1/2" NPT OR M20 OR 3/4" NPT (Select any one)
Mounting	Wall mounting / slab mounting type
Gas group	IIA & IIB + H2 , Zone 1 & Zone 2
Application	Hazardous area
Weather protection	IP 65

Flameproof Instrumentation

Plot. No. E/14, Addl. MIDC, Anand Nagar, Ambarnath (E), Dist. Thane, Maharashtra, India — 421 506.,

sales@flameproof.co.in

9321160178

www.flameproof.co.in

Internal Dimension / Space Available for Camera fitment

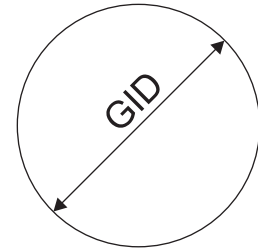
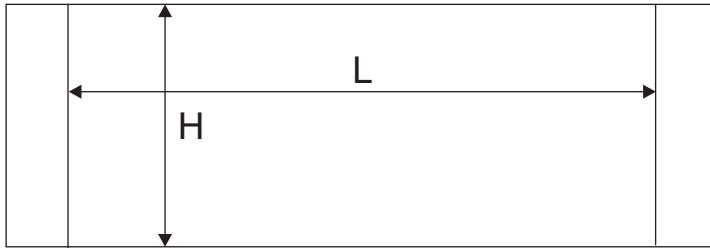

L	H	GID
350mm	125mm	115mm

L - Maximum Available Length

H - Maximum Available Height

GID - Maximum Glass Internal diameter

Flameproof Instrumentation

 Plot. No. E/14, Addl. MIDC, Anand Nagar, Ambarnath (E), Dist. Thane, Maharashtra, India — 421 506.,

 sales@flameproof.co.in

 9321160178

 www.flameproof.co.in